

Installation Instructions

K5123A

2006-2007.5 Chevy 6.6L Cat Back 5” with Turbo Direct Pipe

Tools needed: 9/16” end wrench or socket, hacksaw or sawzall, aerosol lubricant.
(If your vehicle is equipped with a catalytic converter, it is unlawful to remove.)

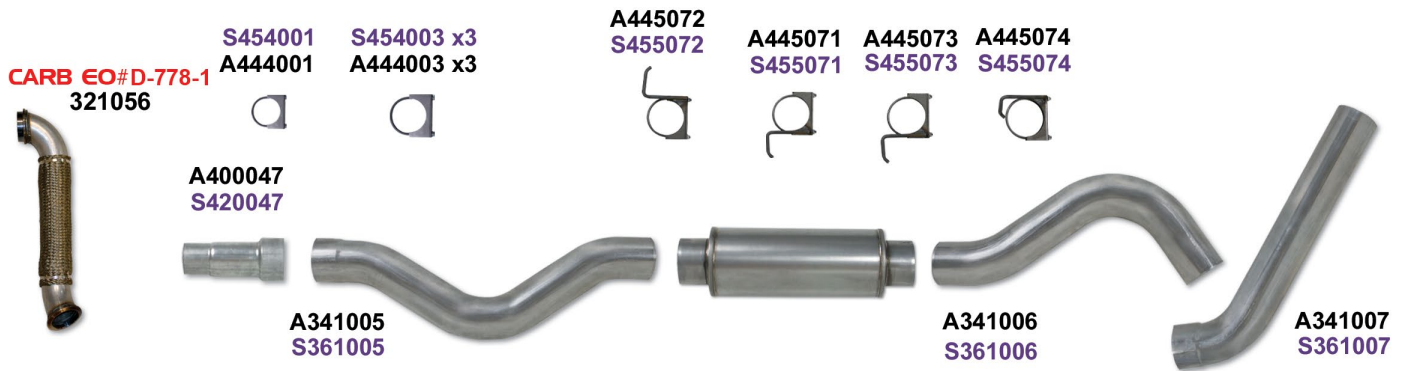

Removal of Original System

- 1) Start under the vehicle. Remove the 3 ½” band clamp just behind the catalytic converter.
- 2) Cut the original system just behind the muffler.
- 3) Spray the stock hangers with aerosol lube and pry rubber mounts from the system. Leave the rubber mounts attached to the truck for re-use.
- 4) Remove the old system.
- 5) Remove factory turbo direct pipe by unbolting it from the turbo and the front pipe.

Installation of New Performance System

(Hint: Do not fully tighten any clamps until the complete system is installed and aligned.)

- 1) Install turbo direct pipe (321056) to turbo and the front pipe.
- 2) Hang the muffler in the stock location using the hanger clamp (#445073) on the outlet. This determines the placement of the rest of the system.
- 3) Install the first tail pipe (#341006) into the outlet of the muffler using the hanger clamp already installed. Rotate the pipe as needed to pass next to the shock absorber.
- 4) Install the second tail pipe (#341007) on to the outlet of the first tail pipe with a bare clamp. Rotate as needed to level the outlet behind the rear tire. Attach the hanger clamp (#445074) in the stock location.
- 5) Install the cross-member pipe into the inlet of the muffler. Install the hanger clamp in the stock hanger location. Install the adapter in the inlet of the cross-member pipe with a bare clamp.
(On certain cab models, it will be necessary to trim the cross-member pipe to position it around the cross-member.)
- 6) Starting at the converter, align and tighten all the pipes and clamps. Start the engine and check for leaks.