

# Installation Instructions

## K4310S

### 1994-1997.5 Ford 7.3L F250-F350 4" SS Cat Back

Tools needed: 9/16" end wrench or socket, 7/16" deep socket, hacksaw or sawzall, aerosol lubricant.

**(If your vehicle is equipped with a catalytic converter, it is unlawful to remove.)**

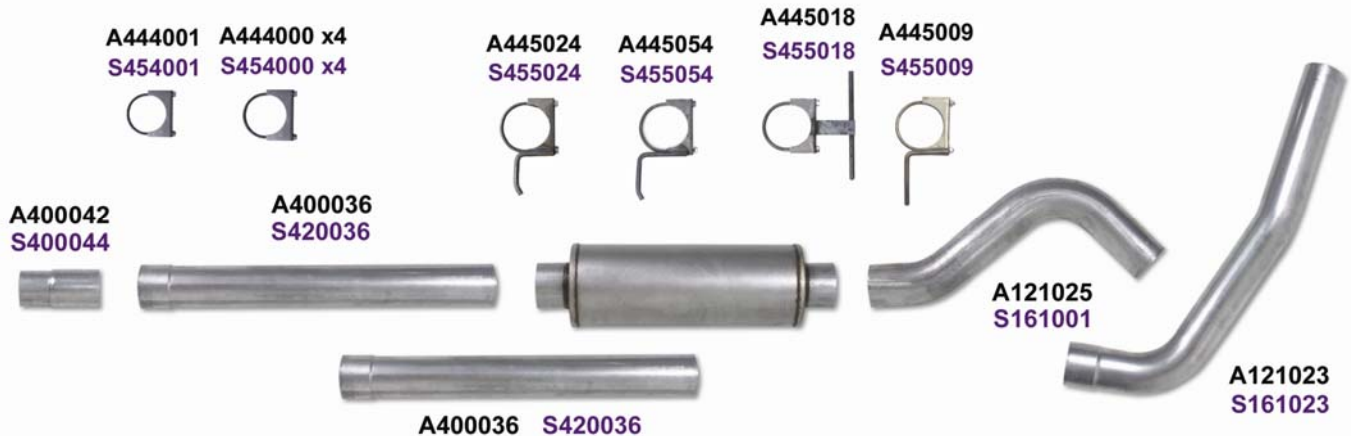

#### Removal of Original System

- 1) From under the truck, cut the intermediate pipe 4" behind the catalytic converter. The new performance system is designed to re-use the catalytic converter.
- 2) Cut the tail pipe just behind the muffler.
- 3) Spray the stock hanger points with aerosol lube and pry rubber mounts from the system. Leave the rubber mounts attached to the truck for re-use.
- 4) Remove the old system.

#### Installation of New Performance System

(Hint: Do not fully tighten any clamps until the complete system is installed and aligned.)

- 1) Attach the adapter to the outlet of the catalytic converter using the 3 1/2" bare clamp.
- 2) Hang the muffler in the stock location using the hanger clamp on the inlet and the hanger clamp on the outlet. This determines the placement of the rest of the system.
- 3) Install the first tail pipe section into the outlet of the muffler using the hanger clamp that is already in place. Rotate the pipe as needed to pass next to the shock absorber and over the rear axle.
- 4) Install the second tail pipe section into the outlet of the first tail pipe section using a bare clamp. Rotate as needed to level the outlet behind the right rear tire. Attach the hanger clamp in the stock location.
- 5) Measure between the outlet of the adapter and the inlet of the muffler. Add 5" to this measurement for the slip-joints and cut the straight pipe to fit. Install the cut pipe between the adapter and the muffler with a bare clamp at the front and using the hanger clamp that is already on the muffler inlet. On longer models it may be necessary to use the additional straight pipe provided. Connect these with a bare clamp.
- 6) Starting at the converter, align all pipes and tighten all clamps. Start the engine and check for leaks.