

Installation Instructions

K4212S

1994-2002 Dodge 5.9L Turbo Back 4" Stainless Steel

Tools needed: 9/16" end wrench or socket, 7/16" deep socket, hacksaw or sawzall, aerosol lubricant, 1/2" drill.
(If your vehicle is equipped with a catalytic converter, it is unlawful to remove.)

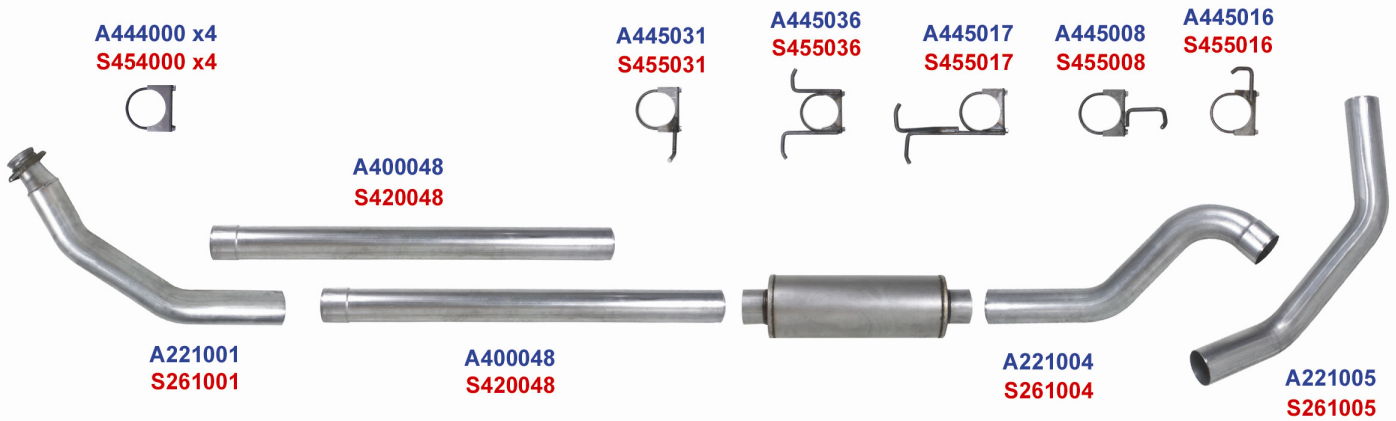

A = Aluminized S = Stainless Steel

Removal of Original System

- 1) Start under the vehicle. Remove the two bolts that hold the stock down pipe to the cast iron elbow on the turbo. Save these bolts for re-use.
- 2) Cut the original system in two places, first next to the transmission and second, just behind the muffler.
- 3) Spray the stock hangers with aerosol lube and pry rubber mounts from the system. Leave the rubber mounts attached to the truck for re-use.
- 4) Remove the old system.

Installation of New Performance System

(Recommended Procedure: Do not fully tighten any clamps until the complete system is installed and aligned.)

- 1) From under the truck, install the down pipe with the stock bolts.
- 2) Install one straight pipe into the muffler inlet and the first tailpipe section into the muffler outlet using the bare clamps.
- 3) Temporarily hang the muffler in the stock location using the hanger clamp on the straight pipe and the hanger clamp on the first tailpipe section.
- 4) Rotate the tailpipe as needed to pass next to the shock absorber and over the rear axle.
- 5) Install the second tailpipe into the outlet of the first tailpipe with a clamp. Rotate as needed to level the outlet behind the right rear tire. Attach the hanger clamp to the second tailpipe using the rubber in the stock location.
- 6) Measure between the outlet of the down pipe and the inlet of the straight pipe. (Add 5" to this measurement for the slip-joints.)
- 7) Cut the next straight pipe to length and install between the down pipe and the straight pipe already installed using a clamp at the down pipe and one on the straight pipe inlet.
- 8) Starting at the turbo, align all pipes and tighten all clamps. Start the engine and check for leaks.

Rev. MPN 4-10-07