

Installation Instructions

K3420A

2007-2009 Toyota Tundra 5.7L 3.5" Alum. Single

Tools needed: standard and metric deep socket set, hacksaw or sawzall, aerosol lubricant.

(If your vehicle is equipped with a catalytic converter it is unlawful to remove.)

(Check local laws concerning exhaust modifications)

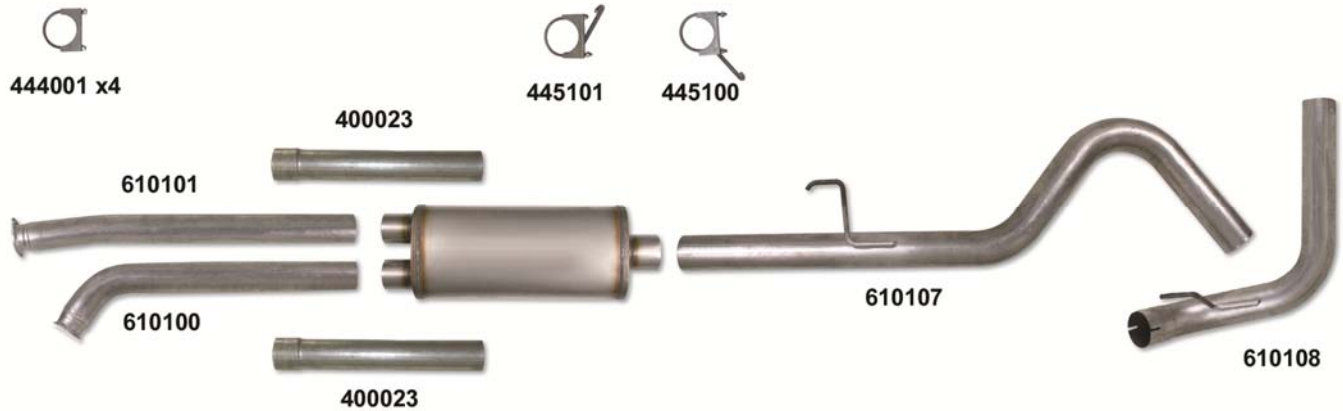

Removal of Original System

We suggest that a trained professional remove and install your exhaust.

- 1) Start under the vehicle behind the four stock converters. Remove the bolts from the driver side flange and passenger side flange that connect both of the intermediate pipes to the forward section.
- 2) Be sure to save the inner compression ring between each flange and the four bolts for reinstallation.
- 3) Unbolt and remove the band clamp behind the stock muffler and separate the system.
- 4) Spray the stock hangers with aerosol lube and pry system from the rubber mounts starting with the intermediate pipe and stock muffler section.
- 5) Next pry and remove the tailpipe section from the rubber mounts.
- 6) Leave the rubber mounts attached to the truck for re-use.

Installation of New Performance System

(Do not fully tighten any clamps until the complete system is installed and aligned.)

- 1) From under the truck, hang the muffler in the stock location with the dual end facing forward using the hanger clamps on the muffler inlets. This will determine the placement of the rest of the system.
- 2) Hang the first section tailpipe behind the muffler using the stock rubber mount.
- 3) Install the inlet into the single outlet of the muffler with a bare clamp.
- 4) Hang the second section tailpipe in the stock rubber mount
- 5) Install inlet into the outlet of the first section tailpipe with a bare clamp.
- 6) Install the passenger side intermediate pipe with the stock bolts and trim the end of the pipe to fit inside the passenger side inlet of the muffler. (When trimming intermediate pipe, be sure to leave enough pipe inside muffler inlet for clamping and sealing purposes. Usually 2-3 inches)
- 7) Install the driver side intermediate pipe with the stock bolts and trim the end of pipe to fit inside driver side inlet of the muffler.
- 8) Longer cab or bed models may require the use of the 24" IP pipes.
- 9) Starting at the flanges, align and tighten all the pipes and clamps. Start the engine and check for leaks.